

Dimensions in Inches, Tolerances: .XX ± .03 .XXX ± .010

**DC CURRENT TRANSDUCER
MODEL S1068
4 to 20mA 2 WIRE LOOP POWER**

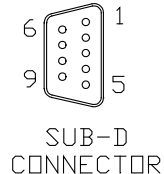
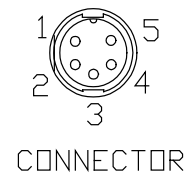
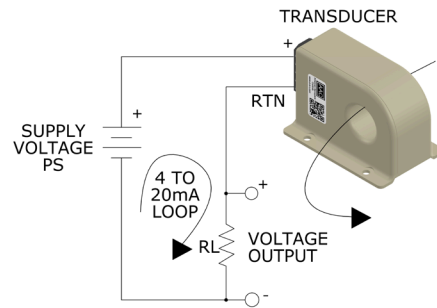
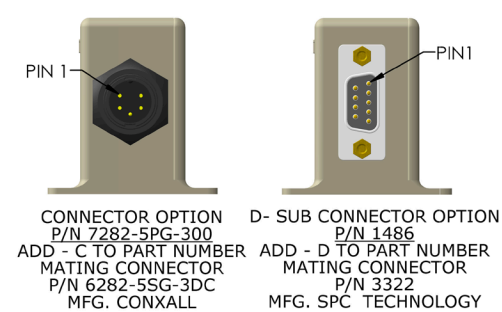
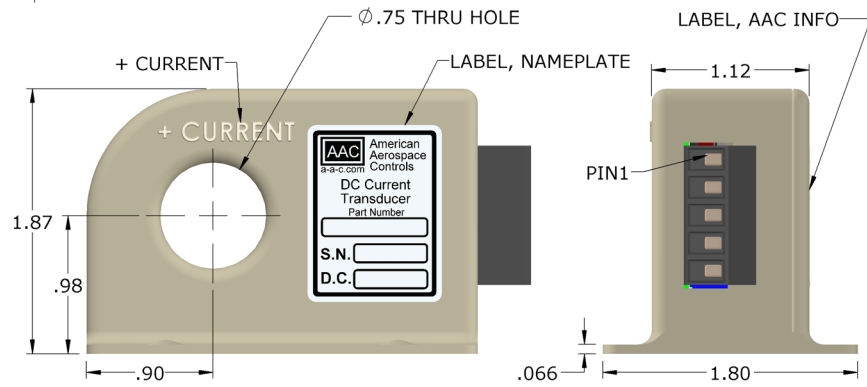
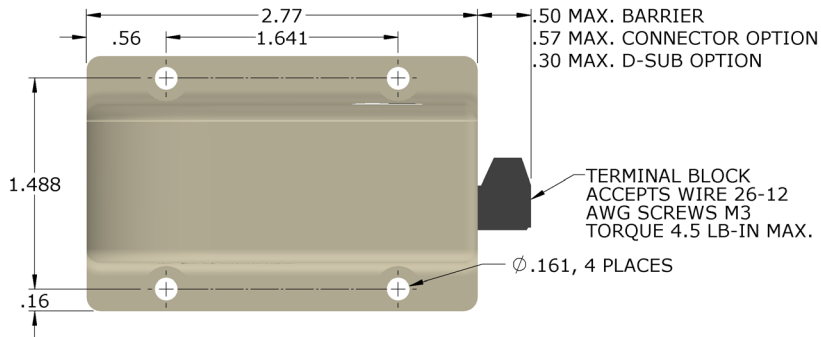

TERMINAL IDENTIFICATION

1. SUPPLY (+)
2. SUPPLY (RTN)
- 3-9. SPARE

PART NUMBER	CURRENT RANGE
S1068-10	0 to 10
S1068-20	0 to 20
S1068-25	0 to 30
S1068-30	0 to 30
S1068-40	0 to 40
S1068-50	0 to 50
S1068-75	0 to 75
S1068-100	0 to 100

INPUT

RANGE	Adc (see table)
OVERLOAD	±500Adc

OUTPUT

CURRENT SIGNAL	4 to 20mAdc FS
ACCURACY	±1% FS max. (± 200uA)
RESPONSE (10 to 90%)	50 u-sec. max.
LOAD RESISTANCE (RL)	250 Ohms Nominal
LOAD RESISTANCE RANGE	0 to 300 Ohms
TEMPERATURE COEFFICIENT	±0.02%FS/°C
CURRENT SIGNAL @ OVERLOAD	23mAdc typ.
OUTPUT PROTECTION	Reverse Polarity Protection

POWER SUPPLY

SUPPLY VOLTAGE	+24Vdc
CURRENT DRAIN	4 to 23mAdc
SUPPLY VOLTAGE RANGE	+22 TO +32Vdc

ENVIRONMENTAL AND PHYSICAL CHARACTERISTICS

MEAN TIME BETWEEN FAILURES	5.55 Million hours per RIAC 217 Plus
OPERATING TEMPERATURE RANGE	-40° to +85°C
STORAGE TEMPERATURE RANGE	-45° to +85°C
HUMIDITY (Operating)	0% to 95%RH
MOISTURE RESISTANCE	MIL-STD-202 Method 106 (note 1)
TRANSIENT BURST	±2KV Peak Per EN 50155 Para.12.2.7.3
VOLTAGE SPIKE	DO-160E Cat A (±600V Spikes)
RANDOM VIBRATION (Operating)	MIL-STD-810F, Proc.1,Cat.12, WO=.095G ² /Hz, Time1 hr, Fig. 514.5C-8 Overall level 12.G- RMS
SHOCK	50g 11m-sec. half sine pulse
ISOLATION	Input to output 5KV rms 60Hz/1min.
INSULATION RESISTANCE	500 M-Ohms @ 500Vdc
CASE MATERIAL	Molded Plastic meets UL flammability rating 94V-O (color light gray)
WEIGHT	6 oz. Max.

NOTE 1: Meets Specified Moisture requirements with option C & D only.

AAC	Drawing Number S1068	Rev. B
------------	---------------------------------------	-------------------------