

Dimensions in Inches, Tolerances: .XX ± .03 .XXX ± .010

**BIDIRECTIONAL CURRENT SENSOR
SERIES 944**

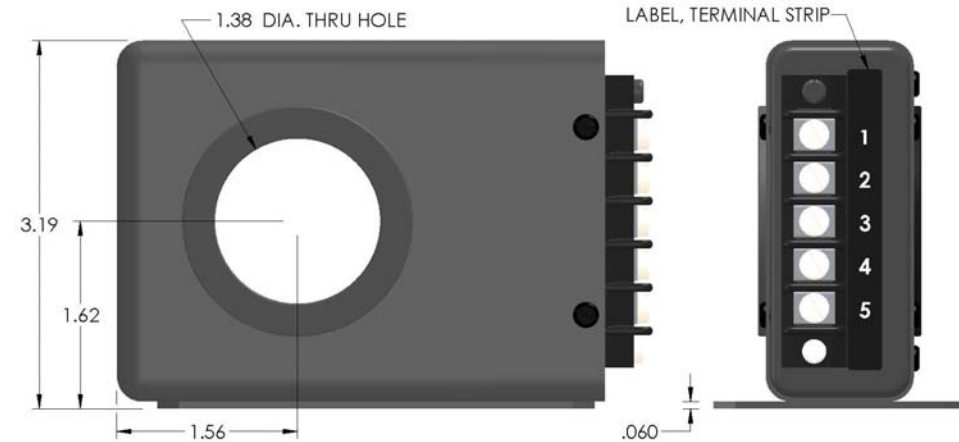

CONNECTOR OPTION
ADD "-C" TO
MODEL NO.
CONNECTOR P/N
PT02E-10-6P-023
OR EQUIV.
MATING CONNECTOR
MS3116F-10-6S
OR EQUIV.

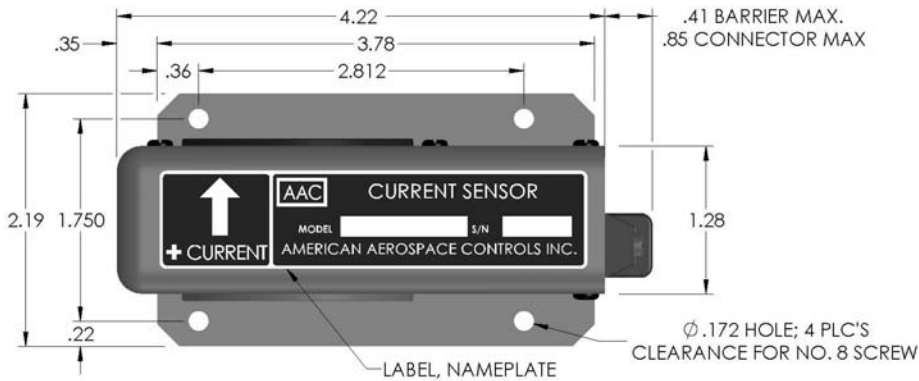
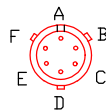

TERMINAL IDENTIFICATION

- 1- A. SUPPLY VOLTAGE (+)
- 2- B. SUPPLY & OUTPUT (RTN)
- 3- C. SUPPLY VOLTAGE (-)
- 4- D. OUTPUT SIGNAL (+)
- 5- E. CASE GROUND
- F. SPARE

<u>PART NUMBER</u>	<u>INPUT RANGE</u>
944-600	0 TO ±600
944-800	0 TO ±800
944-1000	0 TO ±1000
944-1500	0 TO ±1500
944-2000	0 TO ±2000

INPUT CURRENT

RANGE Amps. DC or AC peak. See Table
CURRENT OVERLOAD ±5000 Amps. DC continuous.
FREQUENCY DC to 20KHz

OUTPUT

VOLTAGE SIGNAL 0 to ±5Vdc FS (Full Scale)
ACCURACY ±1% FS
LINEARITY ±.5% FS
DI DT CAPABILITY 25A per u-sec
OUTPUT IMPEDANCE 100 Ohms max.
TEMPERATURE COEFFICIENT ±0.04% FS/°C max.

POWER SUPPLY

SUPPLY VOLTAGE ±15Vdc ±1Vdc
CURRENT DRAIN 50mA max.
REVERSE POLARITY PROTECTION 10µA max. current drain without damage

ENVIRONMENTAL AND PHYSICAL CHARACTERISTICS

OPERATING TEMPERATURE -55° to +85°C
STORAGE TEMPERATURE -55° to +100°C
OPERATING HUMIDITY 0% to 95% RH
MOISTURE RESISTANCE Will meet Method 106 of MIL-STD-202 & Method 507.1, Proc. 1 of MIL-STD-810
ALTITUDE Operating: Sea level to 70,000 ft.
RANDOM VIBRATION Operating MIL-STD-810E Category 5, Proc. 1, WO=0.012G²Hz, Duration 1 hr., Figure 514.4-8
Suggested Vibration levels for high performance Aircraft 12.5 G-RMS composite min.
DIELECTRIC STRENGTH 350V RMS terminals 1-4 to 5 & case
INSULATION RESISTANCE 100 M-Ohms min.
ATTITUDE Unit will perform as specified when mounted in any position.
SHOCK Operating: 50g, 11 m-sec half sine pulse Method 213 Condition A of MIL-STD-202.
WEIGHT 1.5 lbs. Max.

MOLDED TERMINAL BLOCK WITH 5-40 TERMINAL SCREWS, 3/8 IN. CENTER TO CENTER SPACING. ACCEPTS WIRE SIZES TO 14 AWG AND WIRE LUGS UP TO 9/32 IN. WIDE.

AAC	Drawing Number 700-944	Rev. F
------------	-----------------------------------	-------------------