

Dimensions in Inches, Tolerances: .XX ± .03 .XXX ± .010

DC CURRENT LEVEL DETECTOR PART NUMBER S629-50

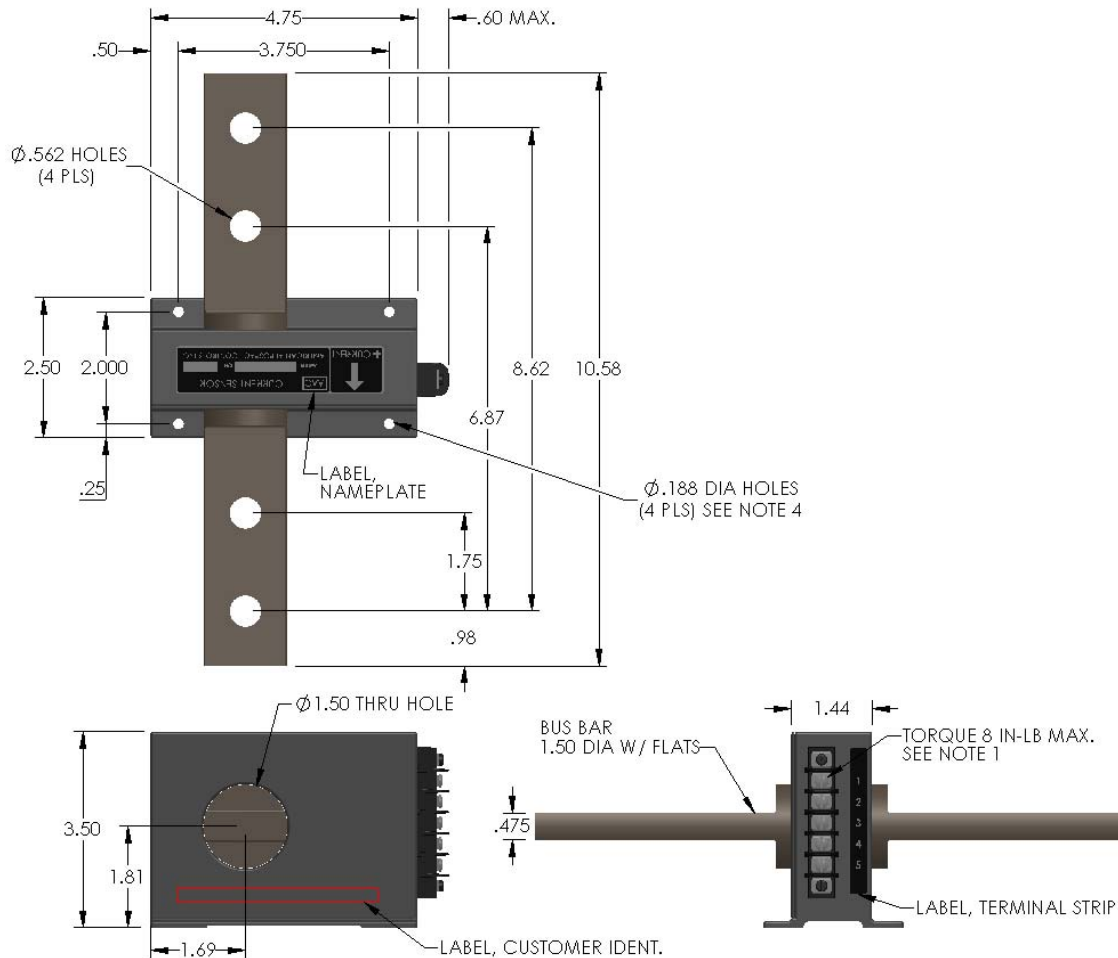

INPUT

RANGE	0 to ± 1000Adc
OVERLOAD / TRANSIENT	± 1422A RMS (1 min) ± 1375A RMS (4 min) ± 1161A RMS (30 min) ± 2168A peak (5 sec.) ± 2514A tr (18 M-sec.)

TRIP POINT

SET POINT	±45Adc
HYSTERESIS	Auto reset 5Adc ±5% below trip point
REPEATABILITY	±0.5 Adc

OUTPUT

RELAY CONTACT (SPST)	Actuated at and above trip point
CONTACT RATING	10amp @ 45Vdc
RESPONSE	50M-sec. MAX.
DIELECTRIC STRENGTH	4000 V RMS coil to contact 1000 V RMS between open contact

POWER SUPPLY

SUPPLY VOLTAGE	+25 to 45Vdc
CURRENT DRAIN	75mA max.
PROTECTION.....	Reverse polarity protected

ENVIRONMENTAL AND PHYSICAL CHARACTERISTICS

OPERATING TEMPERATURE	-25°C to +75°C
STORAGE TEMPERATURE	-40°C to +85°C
SHOCK & VIBRATION	IAW ADTRANZ Doc. ABB-ES-091291-1
OPERATING HUMIDITY	0 to 95% Relative Humidity
INSULATION RESISTANCE	500 M-ohms @ 500Vdc
DIELECTRIC STRENGTH	3.3Kv RMS 60Hz
PRIMARY BAR VOLTAGE	2Kv RMS max.
CASE	Moulded Plastic (GE Lexan) Meets UL Flammability Rating 94 V-0
WEIGHT	6.5 lbs. max.

NOTE:

1. MOULDED TERMINAL BLOCK WITH 5-40 TERMINAL SCREWS, 3/8 IN. CENTER TO CENTER SPACING. ACCEPTS WIRE SIZES TO 14 AWG AND WIRE LUGS UP TO 9/32 IN. WIDE. TORQUE 8 IN-LB MAX.
2. PART TO BE IDENTIFIED WITH ADTRANZ PART NUMBER & REVISION LEVEL IN ACCORDANCE WITH SAE AS478-30, LATEST REVISION. CHARACTER HEIGHT SHALL BE .50 INCH MAX. APPROX. WHERE SHOWN.
3. REFERENCE DOCUMENT NO. E301-005.RFP (XIZ).
4. RECOMMENDED MOUNTING HARDWARE #8 SCREW, #8 SPLIT LOCKWASHER AND #8 FLAT WASHER. TORQUE MAXIMUM 18 IN-LB.

TERMINAL IDENTIFICATION

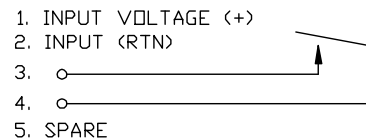

AAC	Drawing Number S629	Rev. E
------------	-------------------------------	------------------