

Dimensions in Inches, Tolerances: .XX ± .03 .XXX ± .010

**AC CURRENT TRANSDUCER
SERIES S383L
4 TO 20mA 2 WIRE LOOP OPERATION**

TERMINAL IDENTIFICATION

1. OUTPUT (+)
2. OUTPUT (RTN)

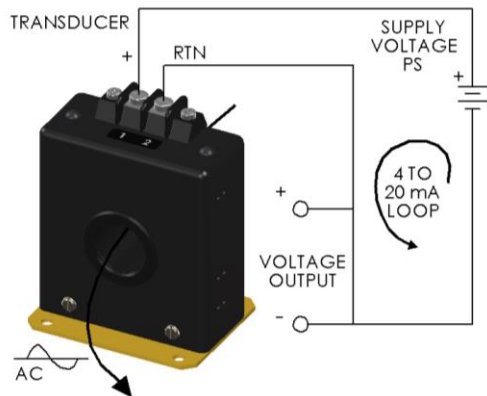
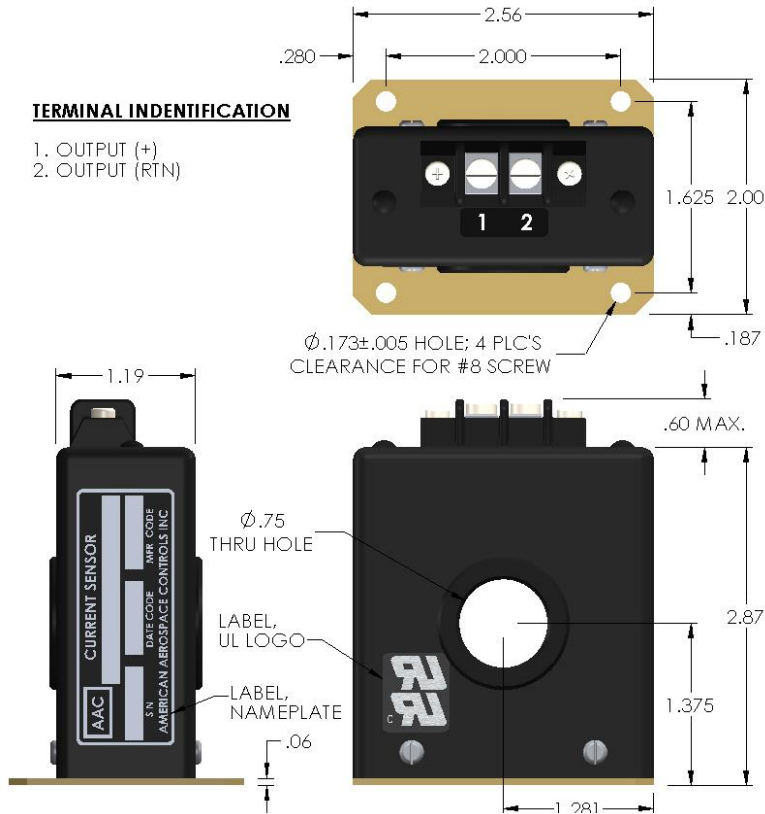

NOTE:
MINIMUM DC SUPPLY VOLTAGE = $7_V + .02 (RL)$
RL = ANY VALUE BETWEEN 0 AND 1400 OHMS.

<u>PART NO.</u>	<u>INPUT RANGE</u>	<u>PART NO.</u>	<u>INPUT RANGE</u>
S383L-50.....	0 to 50mA	S383L-250.....	0 to 250mA
S383L-100.....	0 to 100mA	S383L-500.....	0 to 500mA
S383L-200.....	0 to 200mA	S383L-1A.....	0 to 1A

INPUT

RANGE	Aac See Table
FREQUENCY.....	50 to 60 Hz
OVERLOAD CONTINUOUS.....	250Aac
OVERLOAD TRANSIENT	100 Times Range For 250m-sec.

OUTPUT

CURRENT SIGNAL.....	4 to 20mAac FS (Full Scale)
ACCURACY	$\pm 0.5\% FS$ or $\pm 0.1mA$ max. (Over Temperature Range)
RIPPLE	$\pm 0.25\% FS (\pm 0.05 mA RMS)$
RESPONSE (10 to 90%).....	100mS max.
LOAD RESISTANCE (RL).....	250 Ohms Nominal
LOAD RESISTANCE RANGE	0 to 1400 Ohms (See Note)
CURRENT SIGNAL @ OVERLOAD	30mA TYP.
PROTECTION.....	Reverse Polarity Protected

POWER SUPPLY (PS)

SUPPLY VOLTAGE	15Vdc Nominal
CURRENT DRAIN.....	20mA
SUPPLY VOLTAGE RANGE.....	7 to 35Vdc

ENVIRONMENTAL AND PHYSICAL CHARACTERISTICS

OPERATING TEMPERATURE RANGE	-40° to +85°C
STORAGE TEMPERATURE RANGE ...	-40° to +85°C
ISOLATION.....	Input/Output/Case
INSULATION RESISTANCE	200 M-Ohms @ 500Vdc
INPUT CONDUCTOR VOLTAGE.....	1.5KV max. (5KV max. with insulated cable)
CASE **	Aluminum type 1100-0 (finish corvel lava black 20-7042HY polyester powder coat)
WEIGHT	10 oz. Max.

TERMINAL IDENTIFICATION

1. OUTPUT (+)
2. OUTPUT (RTN)

TERMINAL SCREWS:

5-40 SCREWS, 3/8" CENTER TO CENTER
SPACING ACCEPTS WIRE SIZES UP TO
14 AWG. AND WIRE LUGS UP TO 9/32
WIDE.

AAC

**Drawing Number
S383L-1003AM2**

**Rev.
E**