

Dimensions in Inches, Tolerances: .XX ± .03 .XXX ± .010

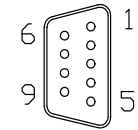

9 PIN D-SUB CONNECTOR

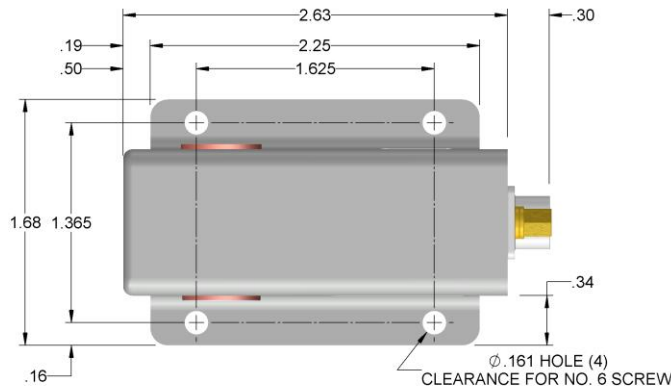
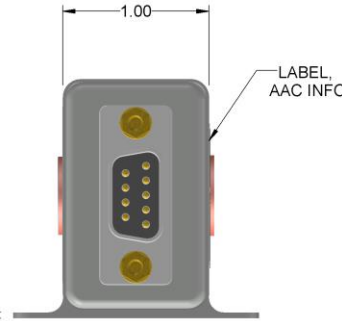
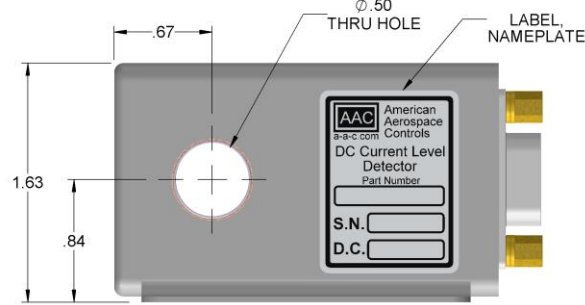

Crash Safety (Sustained) Test Performed IAW RTCA DO-160G, Section 7 at below levels					
Test Levels	FWD	AFT	LAT	UP	DOWN
Sustained	27.21g	N/A	6.8g	4.54g	N/A

Operational Shock & Crash Safety (Impulse) Test Performed IAW RTCA DO-160G, Section 7, Category E

Constant Acceleration Test Performed IAW Mil-Std-810G Method 513 at below levels					
Propeller Aircraft Environment					
Test Levels	FWD	AFT	LAT	UP	DOWN
Operational	1.7g	2.9g	5.75g	4.25g	11.5g
Structural	2.55g	4.35g	8.65g	6.37g	17.25g
Helicopter Environment - Operating @ Structural Levels					
Test Levels	FWD	AFT	LAT	UP	DOWN
Operating	4.0g	4.0g	6.0g	10.5g	4.5g

**TERMINAL IDENTIFICATION**

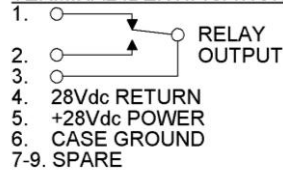

CONTACTS SHOWN WITH INPUT CURRENT ABOVE TRIP POINT (RELAY ENERGIZED)

**Additional Vibration Compliance: Category 13 Propeller Aircraft**  
Vibration Exposure Performed I.A.W MIL-STD-810G, Method 514.6, Figure 514.6 D2, Procedure I

**DC CURRENT LEVEL DETECTOR  
SERIES S1029**

**INPUT**

RANGE..... 0 to ±75Adc  
OVERLOAD CURRENT CONTINUOUS..... ±400Adc  
OVERLOAD CURRENT SURGE..... ±1000Adc 5 sec max.  
DIELECTRIC STRENGTH..... 1000V RMS @ 60Hz max.

**OUTPUT RELAY**

RELAY CONTACT (SPDT)..... Energized at and above trip point  
CONTACT RATING (28Vdc)..... 1 Amp Resistive, 100mA Lamp, 200mA Inductive @ 320mH.  
CONTACT RESISTANCE..... 0.2 Ohm max.  
CONTACT OPEN CIRCUIT VOLTAGE..... 250Vdc  
TRIP POINT OPTION(AS CURRENT INCREASES) .... ±1 to ±75Adc (See Ordering Information)  
TRIP POINT ACCURACY..... ±1% of trip point (See note 1)  
RESET(Accuracy ±1% of trip point)..... Automatic @ 20% below trip point  
RESPONSE TIME (@ 110% of trip point)..... 100 m-sec max.  
OUTPUT ISOLATION..... 350V RMS @ 60Hz

**POWER SUPPLY**

SUPPLY VOLTAGE..... 28Vdc, Normal  
SUPPLY VOLTAGE RANGE..... 18Vdc to 32.2Vdc max  
CURRENT DRAIN..... 75mA max.  
REVERSE POLARITY PROTECTION..... 100µA max. current drain without damage

**ENVIRONMENTAL AND PHYSICAL CHARACTERISTICS**

OPERATING & STORAGE TEMP RANGE..... -55°C to +85°C  
DIELECTRIC STRENGTH..... 350V RMS MIL-STD-202 Method 301  
MOUNTING..... Rigid in any position  
INSULATION RESISTANCE (Test Condition A)..... 200 M-Ohms min. MIL-STD-202 Method 302  
WEIGHT..... 9 oz. max. (1 oz mating connector)  
FINISH..... Fuse tin plate (lead alloy 4% to 12% max)

**DO-160G ENVIRONMENT**

TEMPERATURE & ALTITUDE  
TEMPERATURE VARIATION  
HUMIDITY  
SHOCK & CRASH SAFETY  
VIBRATION  
EXPLOSION PROOFNESS  
WATER PROOFNESS  
SAND & DUST  
FUNGUS RESISTANCE  
SALT FOG

**SECTION**

4  
5  
6  
7  
8  
9  
10  
12  
13  
14  
24  
15  
16  
26  
17  
18  
19  
20  
21  
22  
25

**CATEGORY**

B2 & D2  
A & B  
B  
D & E  
U2  
H  
Y  
D  
F  
S  
A  
Z  
B & Z  
C  
A  
B  
ZC  
R  
M  
A3G33  
A

**Note 1:** Specified accuracy includes the combined worst case effects of Current Cable Positioning, Supply Voltage Range, Temperature Range and Input Frequency Range.

**ORDERING INFORMATION**

S1029 - SERIES ▲ ▲ TRIP POINT AMPS DC  
Trip point option from ±1A to ±75Adc, in 1 amp increments

ie: **S1029-50** Current Level Detector trips @ ±50Adc and reset @ 40Adc

<b>AAC</b>	<b>Drawing Number</b> <b>1029-800</b>	<b>Rev.</b> <b>F</b>
------------	--	-------------------------