

Dimensions in Inches, Tolerances: .XX ± .03 .XXX ± .010

**BIDIRECTIONAL CURRENT SENSOR
SERIES 943A**

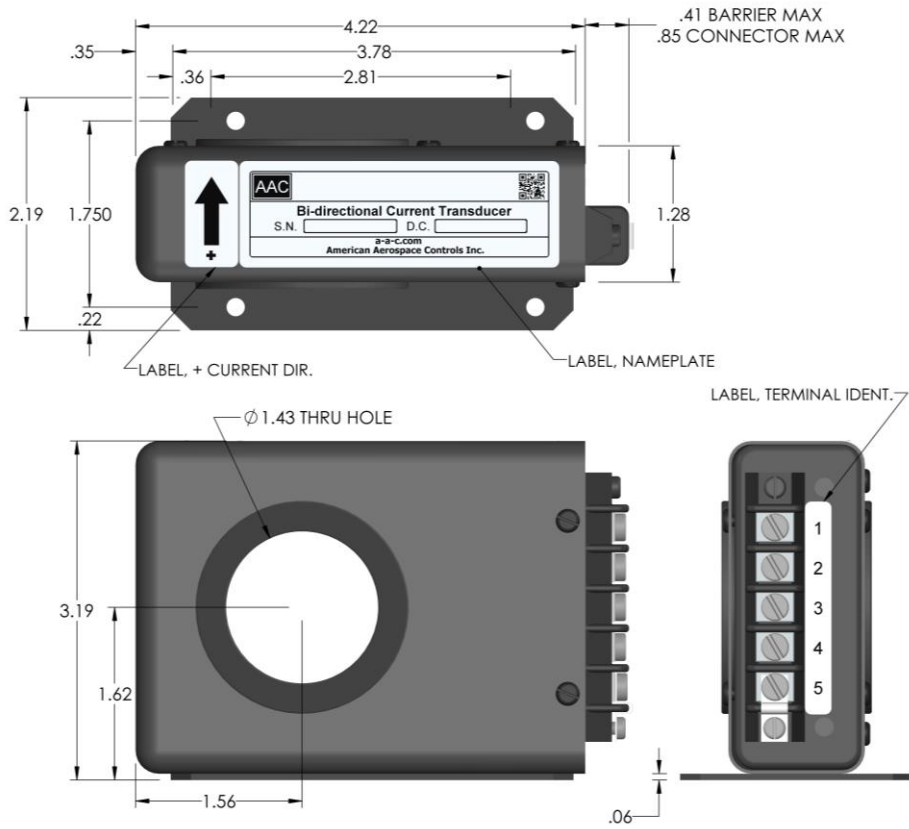

<u>PART NO.</u>	<u>INPUT CURRENT</u>	<u>TEMPERATURE COEFFICIENT</u>	<u>SUPPLY CURRENT</u>
943-100	0 to ±100	.04%	85mA
943-200	0 to ±200	.04%	115mA
943-300	0 to ±300	.02%	165mA
943-400	0 to ±400	.02%	215mA
943-500	0 to ±500	.02%	265mA
943-600	0 to ±600	.01%	265mA
943-750	0 to ±750	.01%	265mA
943-800	0 to ±800	.01%	265mA
943-1000	0 to ±1000	.01%	265mA

INPUT CURRENT

RANGE Amps. DC or AC peak. See Table
 CURRENT OVERLOAD ±5000 amps. DC continuous
 FREQUENCY DC to 350KHz

OUTPUT

VOLTAGE SIGNAL 0 to ±5Vdc FS (Full Scale)
 ACCURACY ± 0.5% FS
 LINEARITY ±0.1% FS
 BANDWIDTH DC to 350KHz
 RESPONSE TIME (10 to 90%) 1 u-sec
 OUTPUT IMPEDANCE 100 Ohms max.
 TEMPERATURE COEFFICIENT % FS per °C. See Table

POWER SUPPLY

SUPPLY VOLTAGE ±15Vdc ±1Vdc
 CURRENT DRAIN See Table mA max.
 REVERSE POLARITY PROTECTION 10µA max. current drain without damage

ENVIRONMENTAL AND PHYSICAL CHARACTERISTICS

OPERATING TEMPERATURE - 55° C to +85° C
 STORAGE TEMPERATURE - 55° C to +100° C
 OPERATING HUMIDITY 0% to 95% RH
 MOISTURE RESISTANCE Will meet Method 106 of MIL-STD -202 & Method 507.1, Proc. 1 of MIL-STD-810
 ALTITUDE Operating: Sea level to 70,000 ft.
 RANDOM VIBRATION Operating MIL-STD-810E Category 5, Proc. 1, WO=0.012G²Hz, duration 1 Hr. Figure 514. 4-8 suggested vibration levels for high performance Aircraft 12.5 G-RMS composite min.
 DIELECTRIC STRENGTH 350V RMS terminals 1-4 to 5 & case
 INSULATION RESISTANCE 100 M-Ohms min.
 ATTITUDE Unit will perform as specified when mounted in any position.
 SHOCK Operating: 50g, 11 m-sec half sine pulse Method 213 Condition A of MIL-STD-202
 WEIGHT 1.5 lbs. max.

MOLDED TERMINAL BLOCK WITH 5-40 TERMINAL SCREWS, 3/8 IN. CENTER TO CENTER SPACING. ACCEPTS WIRE SIZES TO 14 AWG AND WIRE LUGS UP TO 9/32 IN. WIDE.

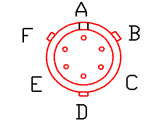
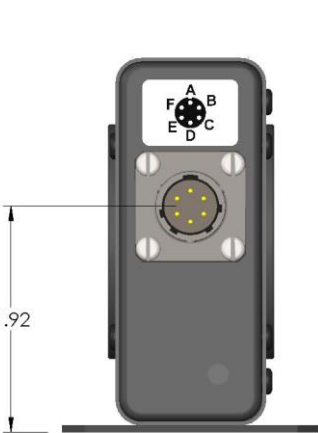

CONNECTOR OPTION
 ADD "C" TO MODEL NO.
 CONNECTOR P/N PT02E-10-6P-023 OR EQUIV.
 MATING CONNECTOR MS3116F-10-6S OR EQUIV.

TERMINAL IDENTIFICATION

- 1- A. SUPPLY VOLTAGE (+)
- 2- B. SUPPLY & OUTPUT (RTN)
- 3- C. SUPPLY VOLTAGE (-)
- 4- D. OUTPUT SIGNAL (+)
- 5- E. CASE GROUND
- F. SPARE

AAC	Drawing Number 943A	Rev. E
------------	--------------------------------	-------------------