

Dimensions in Inches, Tolerances: .XX ± .03 .XXX ± .010

BIDIRECTIONAL CURRENT TRANSDUCER

SERIES S939

REMOVEABLE YOKE TYPE

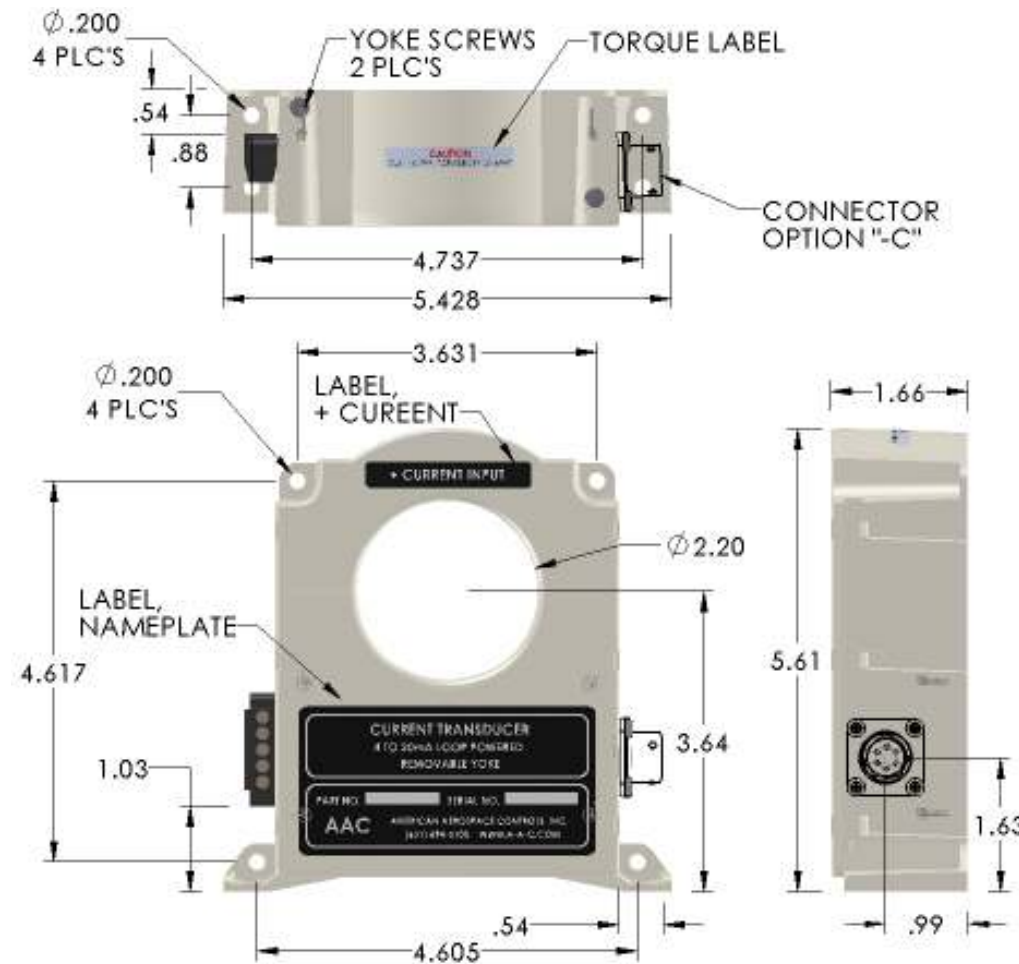

PART NUMBER

PART NUMBER	CURRENT RANGE
S939-500	0 to ±500
S939-750	0 to ±750
S939-1000	0 to ±1000
S939-1500	0 to ±1500
S939-2000	0 to ±2000
S939-2500	0 to ±2500
S939-3000	0 to ±3000
S939-3500	0 to ±3500
S939-4000	0 to ±4000
S939-5000	0 to ±5000

INPUT

RANGE	Adc (See Table)
OVERLOAD	±10kAdc

OUTPUT

VOLTAGE SIGNAL	0 to ±5Vdc FS (Full Scale)
ACCURACY (Over Temperature Range)	%1 FS
RESPONSE (10 to 90%)	200 u-sec. max.
OUTPUT IMPRDANCE	20 Ohms max.
VOLTAGE SIGNAL @ OVERLOAD	6.5Vdc typ.
PROTECTION	Short CKT.

POWER SUPPLY (PS)

SUPPLY VOLTAGE	+11Vdc to +32Vdc
CURRENT DRAIN	20mAdc max.
PROTECTION	Reverse polarity protected
TRANSIENT PROTECTION	±40V (T<10mS)

ENVIRONMENTAL AND PHYSICAL CHARACTERISTICS

OPERATING TEMPERATURE RANGE	-40° to +85°C
STORAGE TEMPERATURE RANGE	-45° to +91°C
HUMIDITY (Operating)	0% to 95%RH
ISOLATION	Input to output 5Kv RMS 60Hz
SHOCK	50g 11m-sec. half sine pulse
INSULATION RESISTANCE	500 M-Ohms @ 500Vdc
DIELECTRIC STRENGTH	5Kvac rms input to output
CASE MATERIAL	Molded Plastic meets UL flammability rating 94V-O (color light gray)
WEIGHT	24 oz. Max.

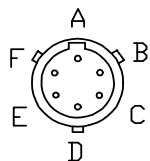

RECOMMENDED MOUNTING SCREWS:
10-32 x 1/4" MIN; TORQUE: 5lb-in;
FLAT AND LOCK WASHERS.

TERMINAL BLOCK

P/N: 120-A-115/05 MFG: WECO (5 PINS)
ACCEPTABLE WIRE: 12-26AWG WIRE
CLAMPING SCREW: M3 SLOT
TORQUE: 4.5MAX in-lb (0.51max Nm)
SCREWDRIVER: 1/8" SLOTTED HEAD 9/16" MIN
SHAFT LENGTH

TERMINAL IDENTIFICATION

BARRIER	CONNECTOR
1. SIGNAL OUTPUT (+)	A
2. OUTPUT (RTN)	B
3. SUPPLY VOLTAGE (+)	C
4. SUPPLY VOLTAGE (RTN)	D
5. SPARE	E
NA. SPARE	F

Terminal 2 & 4 are common

YOKE CAPTIVE SCREWS: 8-32 SLOT
TORQUE: 2 in-lb **CAUTION DO NOT EXCEED.**
SCREWDRIVER: 7/32" SLOTTED HEAD
1 1/2" MIN SHAFT LENGTH

CONNECTOR OPTION
ADD "-C" FOR
CONNECTOR OPTION
P/N PT02E-10-6P-023
MATING CONNECTOR
PT06-10-6S OR EQUIV

AAC

Drawing Number
700-S939-919

Rev.
B