

Dimensions in Inches, Tolerances: .XX ± .03 .XXX ± .010

**AC CURRENT TRANSDUCER
SERIES 1006X
4 TO 20mA 2 WIRE LOOP POWER**

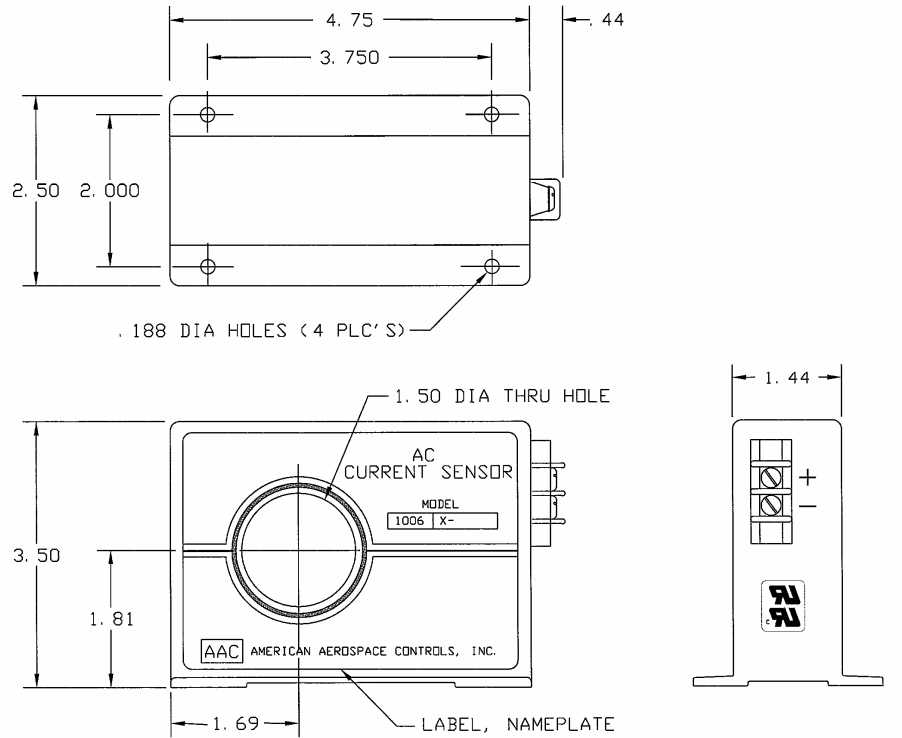

PART NO.	INPUT CURRENT	PART NO.	INPUT CURRENT
1006X-5	0 to 5	1006X-200	0 to 200
1006X-10	0 to 10	1006X-250	0 to 250
1006X-20	0 to 20	1006X-300	0 to 300
1006X-25	0 to 25	1006X-400	0 to 400
1006X-30	0 to 30	1006X-500	0 to 500
1006X-50	0 to 50	1006X-600	0 to 600
1006X-75	0 to 75	1006X-800	0 to 800
1006X-100	0 to 100	1006X-1000	0 to 1000
1006X-150	0 to 150	1006X-1200	0 to 1200

INPUT CURRENT

RANGE..... See Table
 FREQUENCY 50 & 60 Hz
 OVERLOAD CONTINUOUS..... 500Aac or two X FS which ever is greater to a maximum of 1750A

OUTPUT

VOLTAGE SIGNAL..... 4 to 20mA DC FS (Full Scale)
 ACCURACY ±0.5% FS (±0.1mA) Over Temperature Range
 RIPPLE..... .2% FS Typical
 RESPONSE (10 to 90%) 100 m-sec max.
 TEMPERATURE COEFFICIENT ±0.02% FS/°C max.
 LOAD RESISTANCE (RL) 250 Ohms Nominal
 LOAD RESISTANCE RANGE 0 to 1400 Ohms (See Table II)
 REPEATABILITY ±0.1% FS
 CURRENT SIGNAL @ OVERLOAD 30mA Typical
 PROTECTION Reverse Polarity Protected

POWER SUPPLY

SUPPLY VOLTAGE (PS) 15Vdc Nominal
 CURRENT DRAIN 20mA
 SUPPLY VOLTAGE RANGE 10 to 35Vdc (See Table II)

ENVIRONMENTAL AND PHYSICAL CHARACTERISTICS

OPERATING TEMPERATURE RANGE -20° to +70°C
 STORAGE TEMPERATURE RANGE -55° to +85°C
 ISOLATION Input/Output/Case
 CONDUCTOR CABLE VOLTAGE 1.5KV max. (5KV with Insul. Cable)
 CASE Molded Plastic meets UL flammability rating 94V-0
 WEIGHT 1.2 lbs. max.

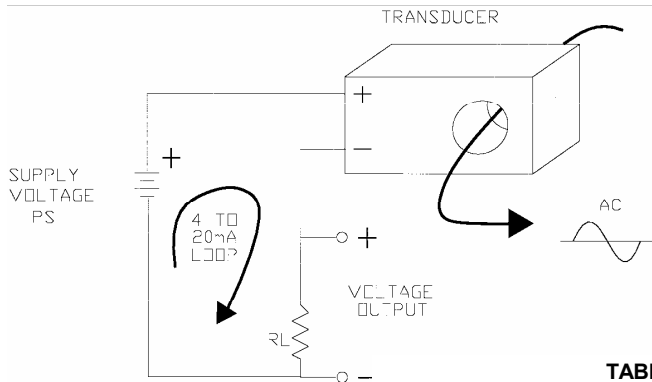

**TABLE II
SUPPLY (PS) VS LOAD RESISTANCE (RL)**

SUPPLY	LOAD RESISTANCE
11Vdc	0 to 250 Ohms
16Vdc	0 to 500 Ohms
21Vdc	0 to 750 Ohms
26Vdc	0 to 1000 Ohms
28Vdc	0 to 1100 Ohms
34Vdc	0 to 1400 Ohms



TERMINALS:

5-40 SCREWS, 3/8" CENTER TO CENTER SPACING,
 ACCEPTS WIRE SIZES UP TO 14 AWG. AND WIRE
 LUGS UP TO 9/32" WIDE.

$RL = VX + (.02)RL$

$VX = 6V$

$RL = 6V + (.02)(1400) = 34Vdc$

AAC	Drawing Number 700-1006X	Rev. L
------------	-------------------------------------	-------------------