

Dimensions in Inches, Tolerances: .XX ± .03 .XXX ± .010

**BIDIRECTIONAL CURRENT TRANSDUCER
SERIES S651**

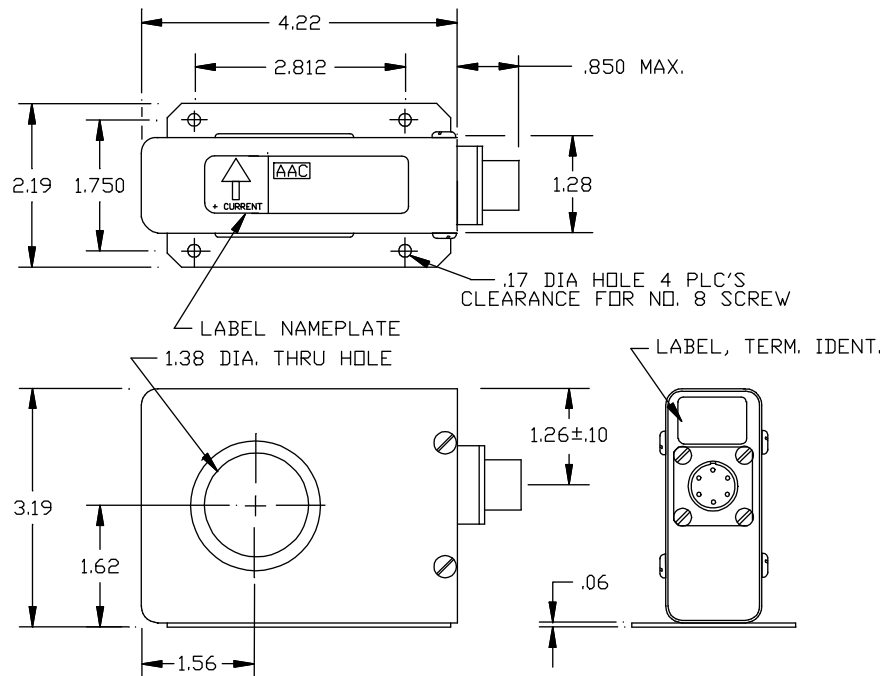

<u>PART NUMBER</u>	<u>INPUT CURRENT RANGE</u>	<u>OVER RANGE</u>
S651-100-C	0 TO ±100Adc	±100 TO ±125Adc
S651-200-C	0 TO ±200Adc	±200 TO ±250Adc

INPUT

RANGE See Table
 OVER RANGE CAPABILITY..... See Table
 CURRENT OVERLOAD..... ± 5000 amps. DC continuous

OUTPUT

VOLTAGE SIGNAL 0 to ± 5Vdc FS (±5 to ±6.25Vdc OR)
 ACCURACY ± 1% (± 50mV) Over -10°C to +65°C
 LOW TEMP. OPERATION..... @ -40°C to -10°C Accuracy / Linearity ±2.5% FS
 ACCURACY OVER RANGE(OR)..... 2.5% FS
 LINEARITY ±0.5% FS
 RESPONSE (10 TO 90%)..... 100 u-sec max.
 OUTPUT LOAD CURRENT 5mA max.
 OUTPUT IMPEDANCE 100 Ω max.

POWER SUPPLY

SUPPLY VOLTAGE +22 to 32Vdc
 CURRENT DRAIN 140mA max.
 REVERSE POLARITY PROTECTION... 10uA max. current drain without damage
 TRANSIENT..... 40V for 20 m-sec

ENVIRONMENTAL AND PHYSICAL CHARACTERISTICS

OPERATING TEMPERATURE -40°C to +65°C
 STORAGE TEMPERATURE..... -55°C to +71°C
 OPERATING HUMIDITY..... 0% to 95% RH
 MOISTURE RESISTANCE Will meet Method 106 of MIL-STD-202 & Method 507.1, Proc. 1 of MIL-STD-810
 ALTITUDE Operating: Sea Level to 27,000 FT.
 Non-Operating: Sea Level to 70,000Ft.
 VIBRATION 20 to 40Hz + 6dB/ Octave 40 to 120Hz 0.02 G²/Hz, 120 to 150 Slope By End Point, 150 to 800Hz 0.04 G²/Hz, 800-2000 Hz -6dB/Octave
 ACCELERATION Operating ±5g's In All Axes, Both Directions
 DIELECTRIC STRENGTH 350V RMS Terminals 1-5 & Case.
 INSULATION RESISTANCE 1 MΩ @ 200Vdc
 ATTITUDE Unit Will Perform As Specified When Mounted In Any Position.
 SHOCK Operating: 20g, Peak Terminal Sawtooth Pulse 11 Milli seconds Duration, All Planes, Both Directions.
 WEIGHT 1.5 lbs. max.

TERMINAL IDENTIFICATION

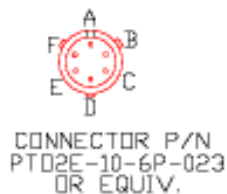

- A. SUPPLY VOLTAGE (+)
- B. SUPPLY (RTN)
- C. OUTPUT (RTN)
- D. OUTPUT SINGAL (+)
- E. CASE GROUND
- F. SPARE

COMPONENTS

DERATING (EEE COMPONENTS)..... Derated To The Intent of Naval Air Systems Command AS-4613.
 MICROCIRCUITS MIL-M-38510 Class B QPL or DESC DWG.
 SEMICONDUCTORS..... MIL-S-19500 (JANTX)
 CAPACITORS..... MIL-C-39003, MIL-C-39014 (Level R)
 RESISTORS MIL-R-39007, -39008, -39035,-55182 (Level R)
 TRANSFORMERS & INDUCTORS..... MIL-T-27 (Class S)

AAC	Drawing Number 700-S651-942	Rev. J
------------	--	-------------------