

**DC CURRENT LEVEL DETECTOR
PART NUMBER S680**

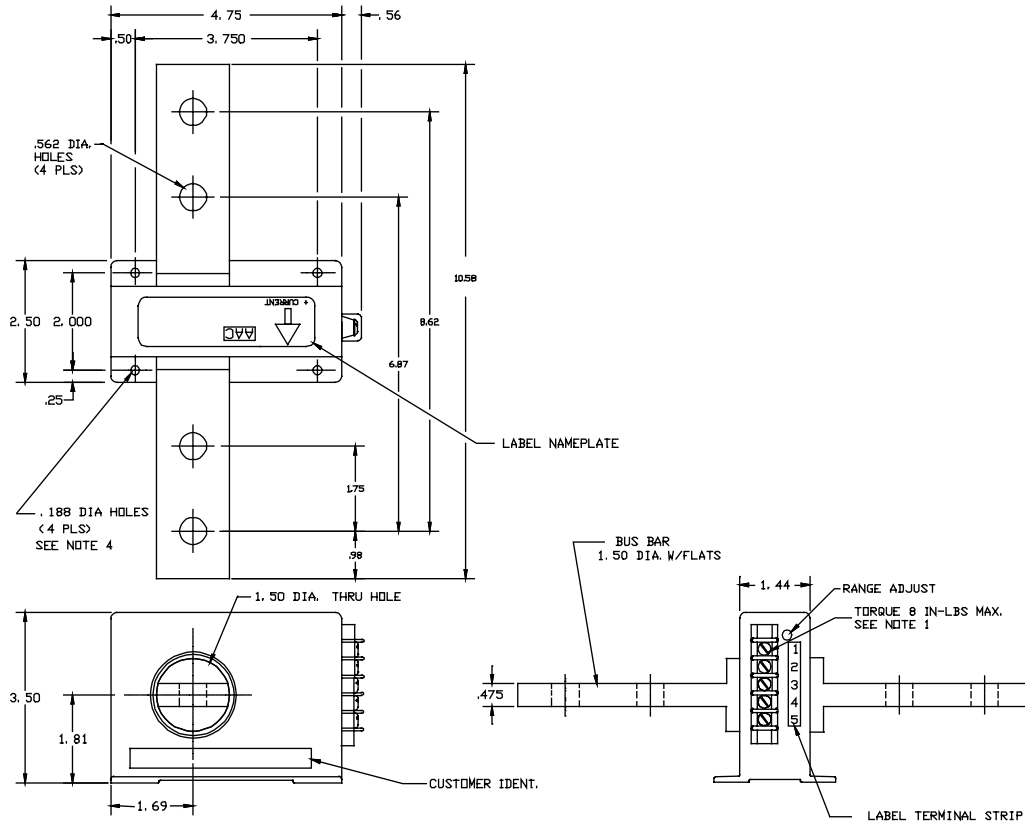

INPUT

RANGE	0 to ± 1000Adc (Continuous)
OVERLOAD / TRANSIENT	± 2004A RMS (1 min) ± 1635A RMS (30 min) ± 2960A Peak (5 sec.)

TRIP POINT SETTING

SET POINT	±3Adc (±10%)
TRIP POINT DELAY (TYPICAL)	350 m-sec. After input (Absolute Value)
Exceeds	Trip Point

ADJUSTMENT RANGE	Field Adjustable ±3 to ±5Adc
------------------------	------------------------------

RESET POINT SETTING

RESET POINT	One Amp (Absolute Value) Below Trip Point
RESET POINT DELAY (TYPICAL)	10 Sec. After Input (Absolute Value) Decreases Below Reset Point

OUTPUT RELAY (Solid State)

RELAY CONTACT (SPST)	Contacts Close at and above trip point
CONTACT RESISTANCE	On 25 Ohms Max, Off 500M Ohms Min.
DIELECTRIC STRENGTH	3.3KV RMS 60Hz
CURRENT LIMIT PROTECTION	Automatically Limits Contact Current to 370mA
OPEN CIRCUIT VOLTAGE	200Vdc OR Peak Max
DUTY CYCLE	Number Of "Change Of State" Operations Is Unlimited.

POWER SUPPLY

SUPPLY VOLTAGE	+25 to 45Vdc
CURRENT DRAIN	25mA max.
TRANSIENT PROTECTION	±60V Peak (30sec.); ±100V Peak (2m sec.)

ENVIRONMENTAL AND PHYSICAL CHARACTERISTICS

OPERATING TEMPERATURE	-25°C to +75°C
STORAGE TEMPERATURE	-40°C to +85°C
SHOCK & VIBRATION	IAW ADTRANZ Doc. ABB-ES-091291-1
OPERATING HUMIDITY	0 to 95% Relative Humidity
INSULATION RESISTANCE	500 M-ohms @ 500Vdc
DIELECTRIC STRENGTH	3.3Kv RMS 60Hz
PRIMARY BAR VOLTAGE	2Kv RMS max.
CASE	Moulded Plastic (GE Lexan) Meets UL Flammability Rating 94 V-0
WEIGHT	6.5 lbs. max.

NOTE:

1. MOLDED TERMINAL BLOCK WITH 6-32 TERMINAL SCREWS, 3/8 IN. CENTER TO CENTER SPACING. ACCEPTS WIRE SIZES TO 14 AWG AND WIRE LUGS UP TO 9/32 IN. WIDE. TORQUE 8 IN-LB MAX.
2. PART TO BE IDENTIFIED WITH ADTRANZ PART NUMBER & REVISION LEVEL IN ACCORDANCE WITH SAE AS478-30, LATEST REVISION. CHARACTER HEIGHT SHALL BE .50 INCH MAX. APPROX. WHERE SHOWN.
3. REFERENCE DOCUMENT NO. E301-005.RFP (XIZ).
4. RECOMMENDED MOUNTING HARDWARE #8 SCREW, #8 SPLIT LOCKWASHER AND #8 FLAT WASHER. TORQUE MAXIMUM 18 IN-LB.
5. YELLOW MARKING PAINTED FOR PROTOTYPE IDENTIFICATION.

TERMINAL IDENTIFICATION

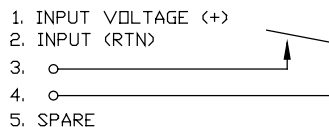

AAC	Drawing Number 700-S680	Rev. D
------------	------------------------------------	-------------------